

LUG & FLAT WASHERS



Designed for the tough
Process Facility
environment

- All Stainless Components
- 180 US Gallon Reservoir
- VFD for Conveyor
- Removable Bulk Filter Screen
- Sanitize Chamber with Manifold
- Washdown Motors & Bearings

Washers **Fully Mobile***

Easy To Use - Adjustable Height - Interchangeable Nozzles

* With Optional Locking Casters



UL 508A
Industrial Control
Panel Fabricator

INNOTECH
Process Equipment
Parts . Sales . Service . Manufacturing

360.393.4108



INNOTECHPROCESSEQUIPMENT.COM

Specifications

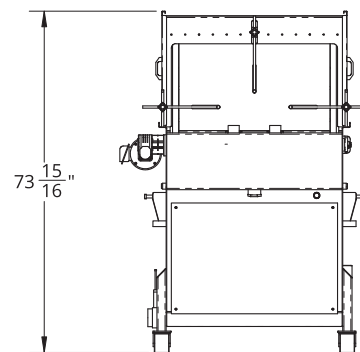
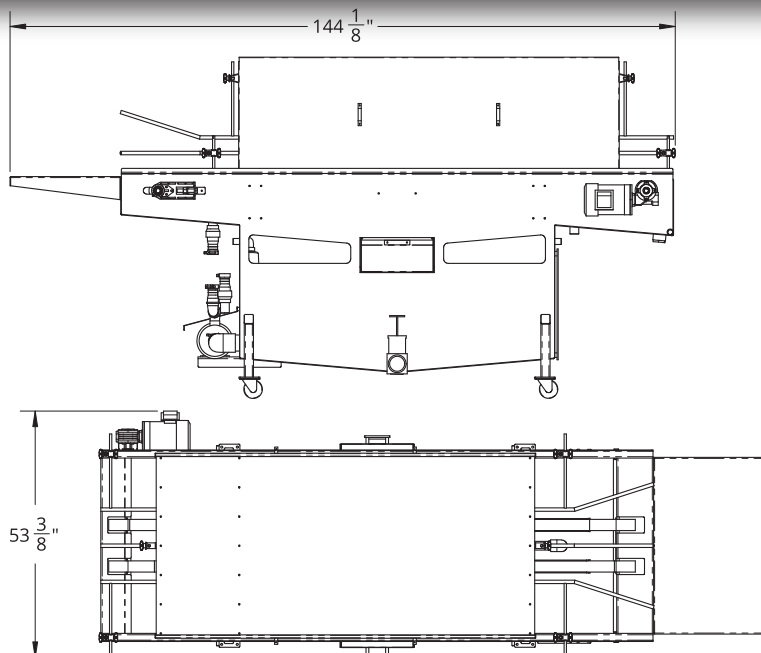

1,645LBS

- Various available power source configurations
- VFD for conveyor
- 180 US Gallon reservoir capacity
- Convenient 3" stainless water drain spout
- Float valve for tank
- All stainless components
- Cogged belt for container transfer
- Removable side panels for easy access to nozzles
- High Efficiency Quick Mount flat spray nozzles
- Available nozzles rated from 20 to 100 PSI
- Completely mobile (with optional casters)
- Removable bulk filter screen
- Nozzles have quick-change tips for cleaning
- Sanitize chamber with manifold

Options:

- Dosatron pumps for sanitizing
- Return conveyor
- Lug rotator
- Washdown locking casters



- Process Equipment Design & Manufacturing
- Engineering & Consulting Services
- Automation & Controls
- Maintenance & Service